



SERIE 200 | **IL NUOVO PIEGHEVOLE**
SERIES 200 | *THE NEW FOLDING DOOR*



SERIE 200 Il nuovo pieghevole

SERIES 200 The new folding door



Sistemi pieghevoli per mobili / Folding systems for furniture

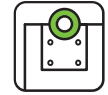
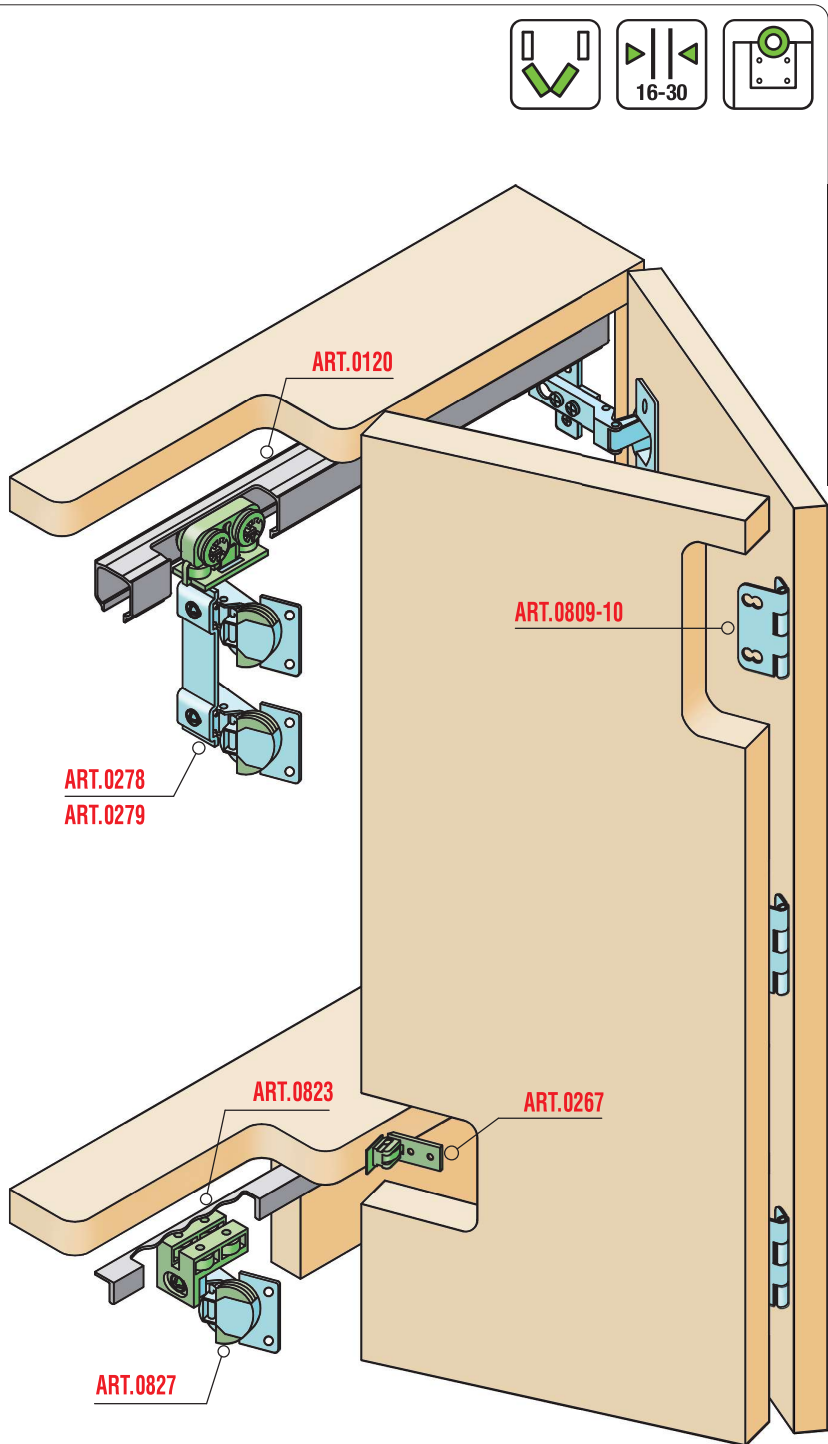
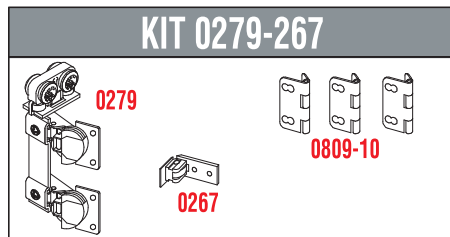
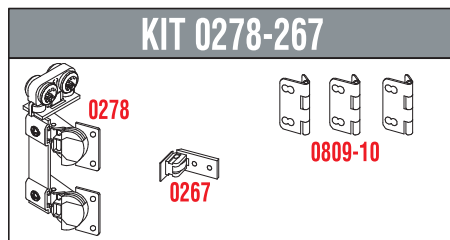
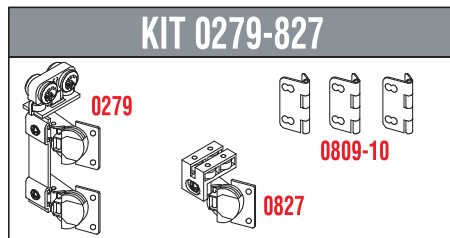
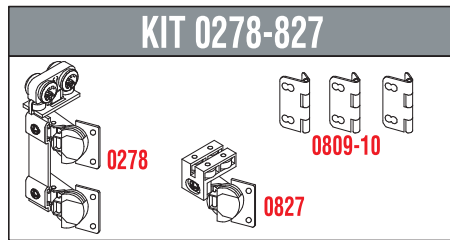

120

Serie 200

Legenda KIT / Kit Legend

0278	Carrello superiore a rulli con 2 cerniere <i>Upper truck with rollers with 2 hinges</i>
0279	Carrello superiore a cuscinetti con 2 cerniere <i>Upper truck with ball bearings with 2 hinges</i>
0267	Rotella inferiore <i>Lower roller</i>
0827	Guida inferiore con 1 cerniera <i>Lower runner with 1 hinge</i>
0809-10	Cerniera simmetrica-asimetrica con bussole <i>Symmetric-asyymmetric hinge with bushes</i>

Legenda altri componenti

Legend other items

0120		Profilo alluminio superiore <i>Upper aluminium profile</i>
0823		Profilo alluminio inferiore <i>Lower aluminium profile</i>

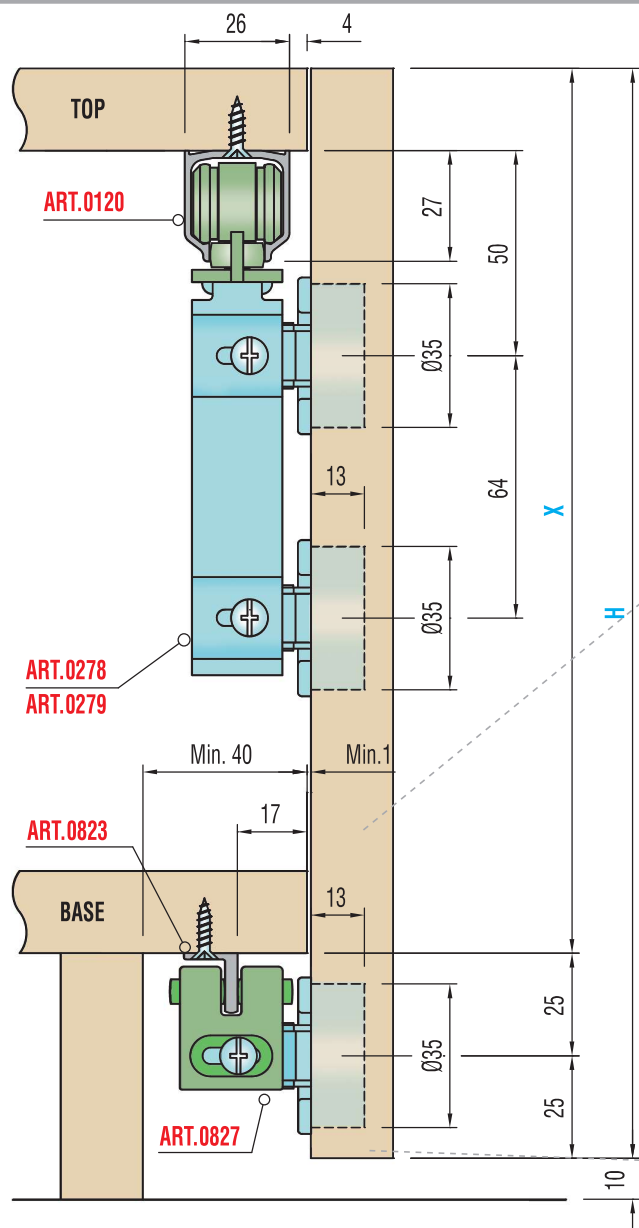
**Sezione verticale / Vertical section**

DIMENSIONI ANTE DIMENSIONS OF THE DOORS	
Altezza Height	max. 2600 mm.
Larghezza Width	max. 500 mm.
Spessore Thickness	min. 16 mm. - max. 30 mm.

**Variante
Special version**

Con guida inferiore all'interno del mobile
With lower runner inside the wardrobe

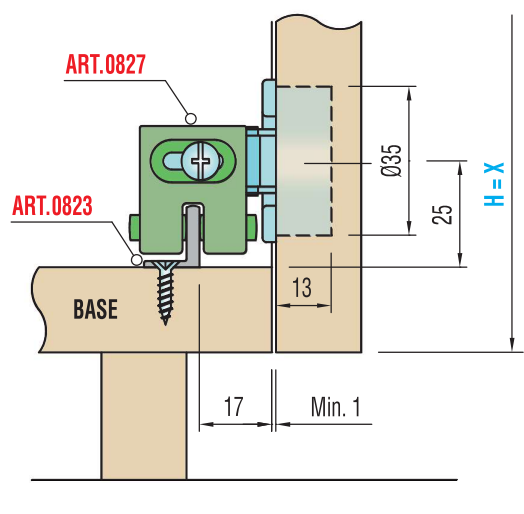

$$H = X + 50$$

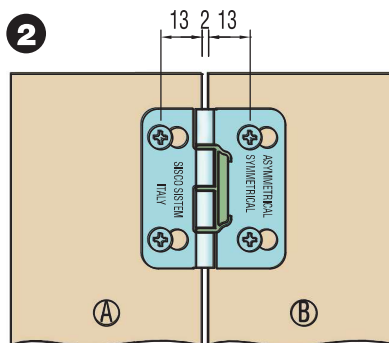
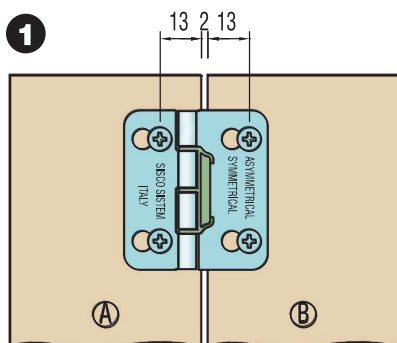
**Posizione di montaggio cerniere centrali art.0809-10
Assembling position of the centre hinges art.0809-10**

Per il corretto funzionamento del sistema, Vi consigliamo l'uso di cerniere laterali con apertura a 110°, in abbinamento alle cerniere centrali, ART.0809-10, montate in modo asimmetrico (1). Se invece utilizzate cerniere laterali con apertura a 90°, montate le cerniere centrali, ART.0809-10, in modo simmetrico (2).

To ensure a proper functioning of the system, we suggest you to use side hinges with 110° opening, along with centre hinges, ART.0809-10, asymmetrically fitted (1). If you use side hinges with 90° opening, fit centre hinges, ART.0809-10, symmetrically (2).

Schema foratura ante / Doors drilling

CON GUIDA INFERIORE ALL'INTERNO DEL MOBILE / WITH LOWER RUNNER INSIDE THE WARDROBE

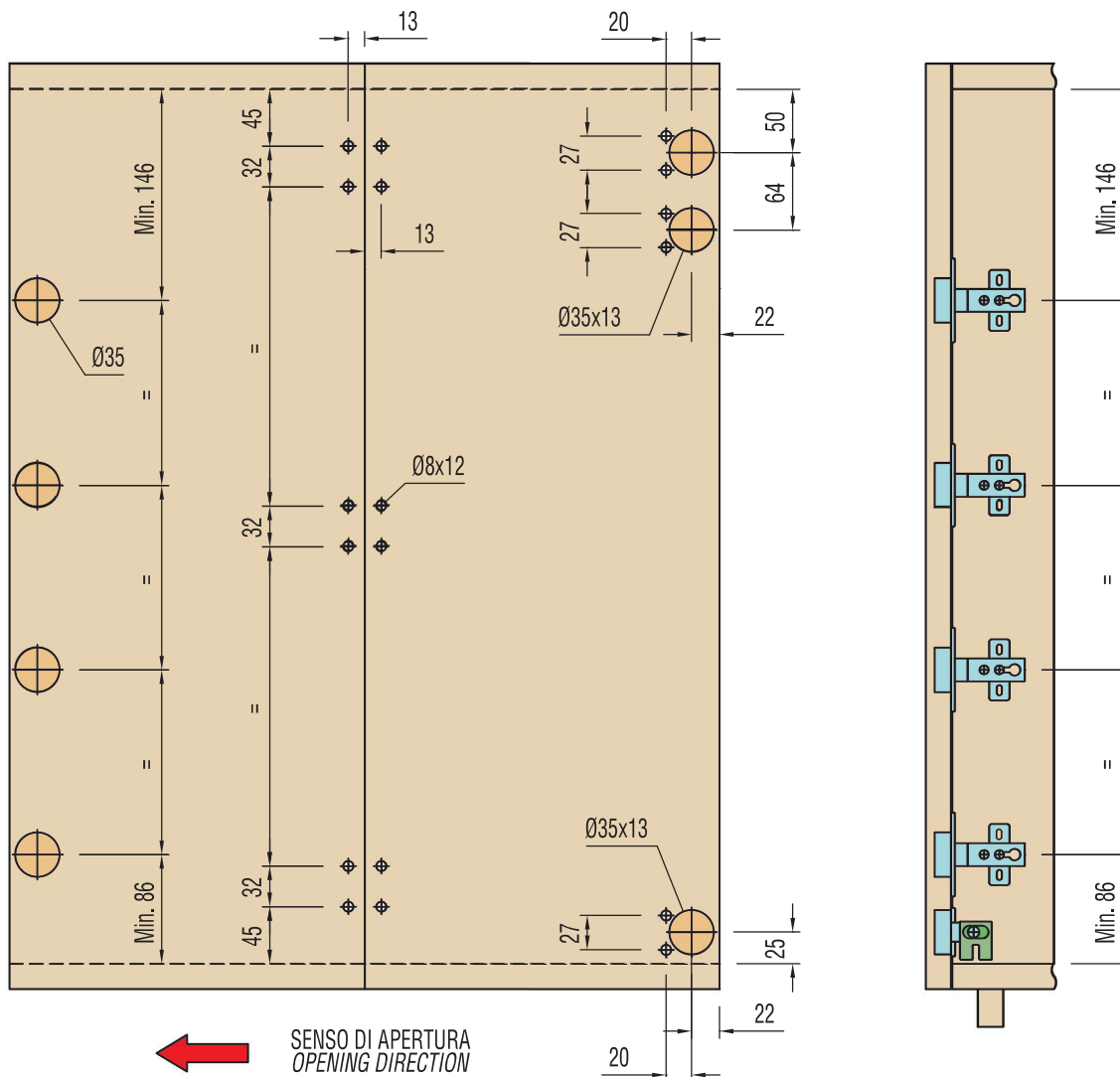

Con guida inferiore all'esterno del mobile / With lower runner outside the wardrobe

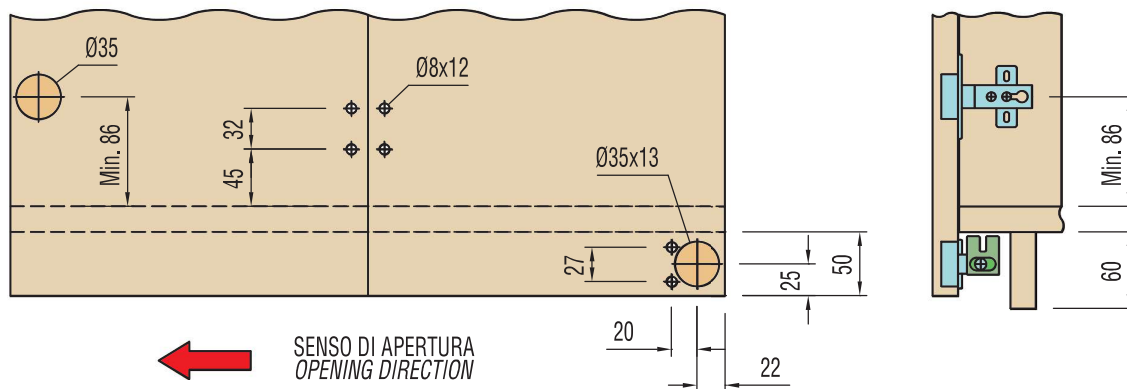

Il peso delle ante deve essere sostenuto dalle cerniere laterali montate sulla spalla del mobile e non dal carrello superiore, che ha la sola funzione di guida. Consultate il vostro fornitore per determinare quante cerniere devono essere montate sulla spalla del mobile, in funzione delle dimensioni e del peso delle vostre ante.

The weight of the doors is born by the side hinges fitted to the wardrobe side, not by the upper truck which only functions as a guide. Turn to your supplier for the quantity of hinges which must be fitted to the wardrobe side, depending on the dimensions and weight of your doors.



Sezione verticale / Vertical section

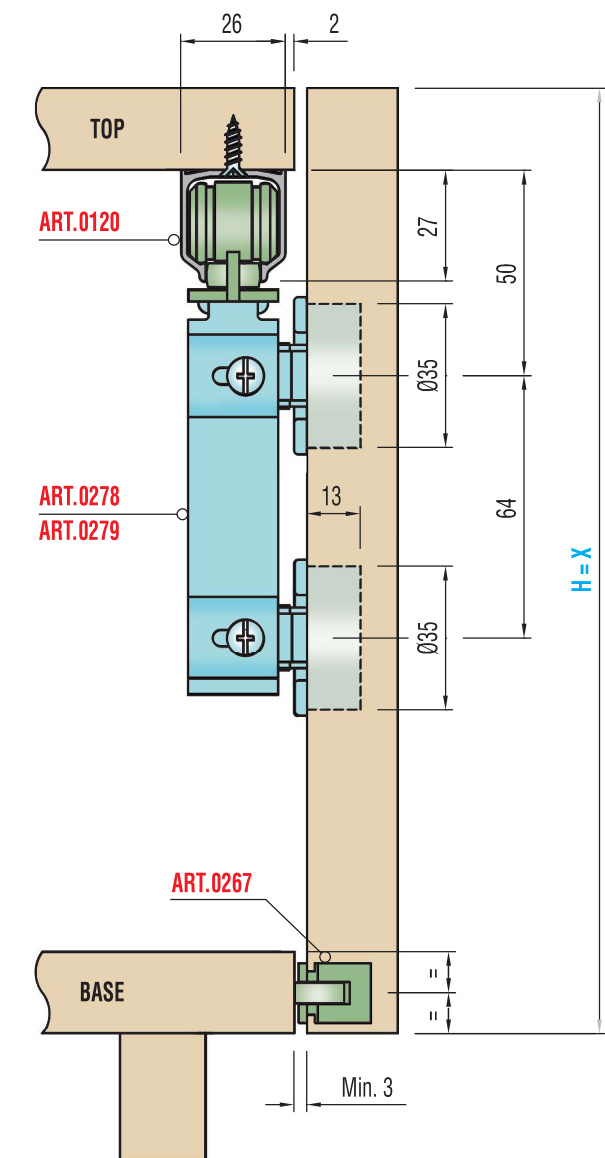

DIMENSIONI ANTE DIMENSIONS OF THE DOORS	
Altezza Height	max. 2600 mm.
Larghezza Width	max. 500 mm.
Spessore Thickness	min. 16 mm. - max. 30 mm.

Dimensione minima di ingombro / Minimum overall dimension

CON ANTE SPESSORE 20 mm
WITH DOOR THICKNESS OF 20 mm.

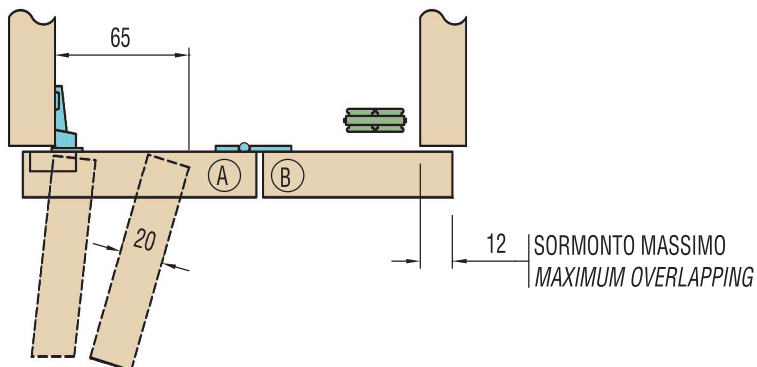

SERIE 200 Il nuovo pieghevole

SERIES 200 The new folding door



Sistemi pieghevoli per mobili / Folding systems for furniture

Schema foratura ante / Doors drilling

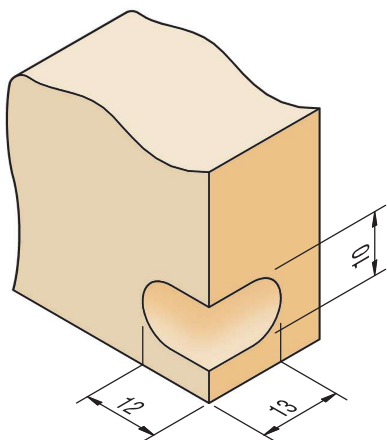
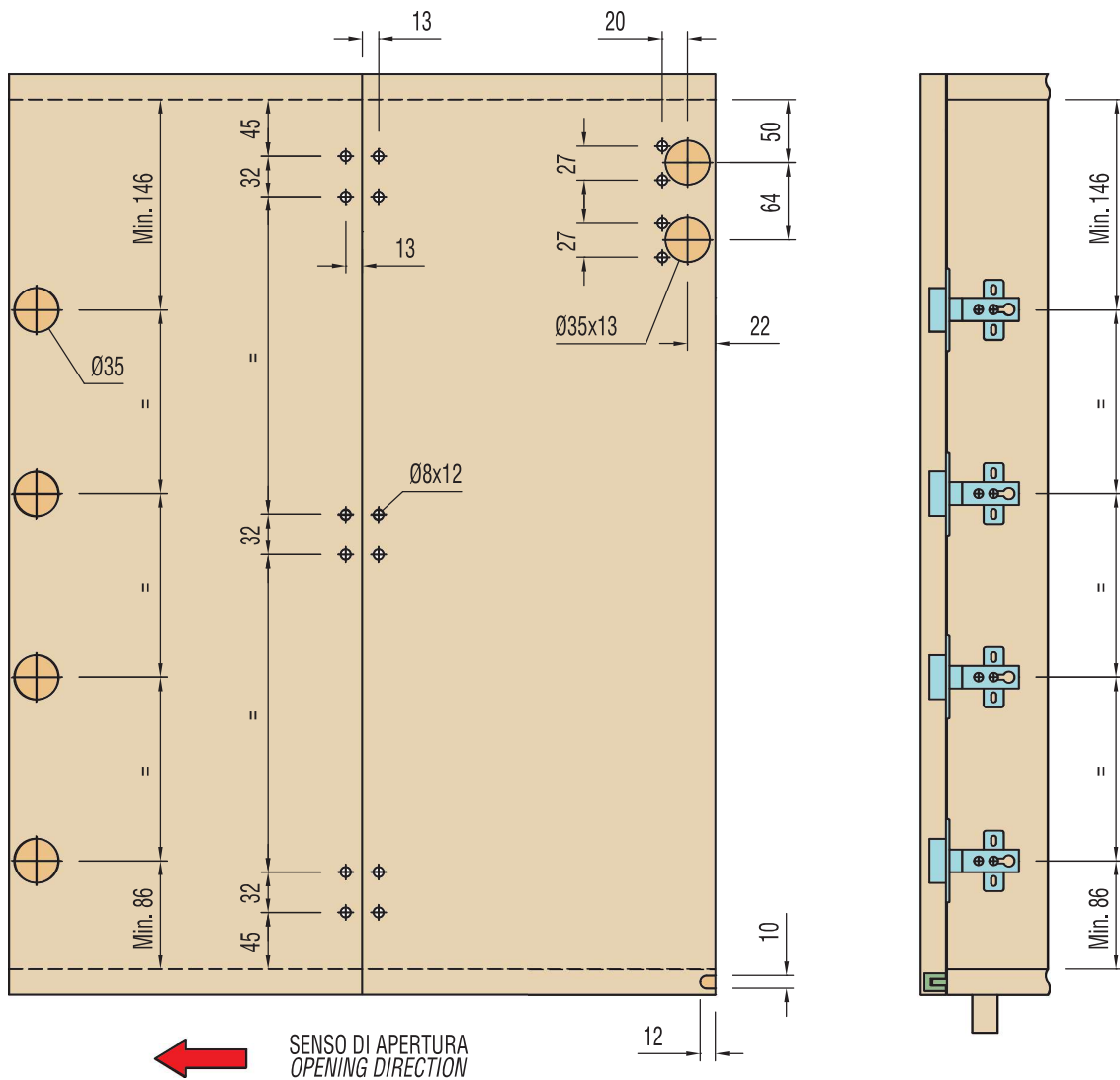

Il peso delle ante deve essere sostenuto dalle cerniere laterali montate sulla spalla del mobile e non dal carrello superiore, che ha la sola funzione di guida. Consultate il vostro fornitore per determinare quante cerniere devono essere montate sulla spalla del mobile, in funzione delle dimensioni e del peso delle vostre ante.

The weight of the doors is born by the side hinges fitted to the wardrobe side, not by the upper truck which only functions as a guide. Turn to your supplier for the quantity of hinges which must be fitted to the wardrobe side, depending on the dimensions and weight of your doors.



KIT 0276-827

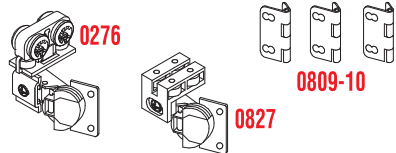

KIT 0277-827

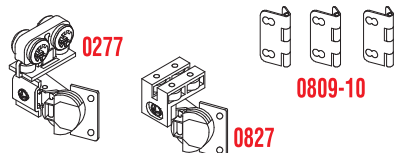

KIT 0276-267

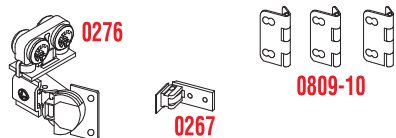

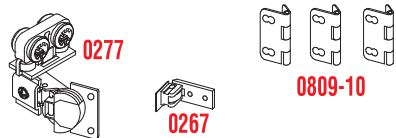

KIT 0277-267



Legenda KIT / Kit Legend

0276	Carrello superiore a rulli con 1 cerniera <i>Upper truck with rollers with 1 hinge</i>
0277	Carrello superiore a cuscinetti con 1 cerniera <i>Upper truck with ball bearings with 1 hinge</i>
0267	Rotella inferiore <i>Lower roller</i>
0827	Guida inferiore con 1 cerniera <i>Lower runner with 1 hinge</i>
0809-10	Cerniera simmetrica-asimmetrica con bussole <i>Symmetric-asymmetric hinge with bushes</i>

Legenda altri componenti Legend other items

0120		Profilo alluminio superiore <i>Upper aluminium profile</i>
0823		Profilo alluminio inferiore <i>Lower aluminium profile</i>

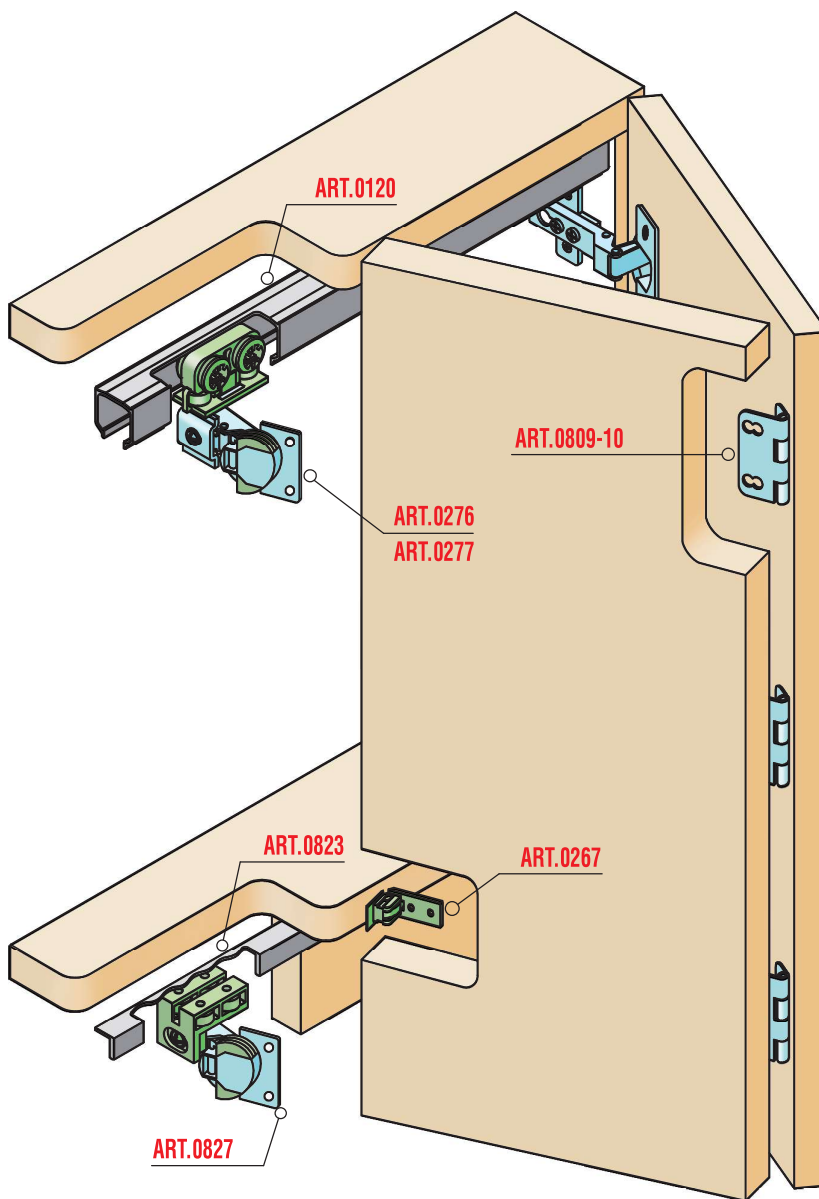

Sezione verticale / Vertical section

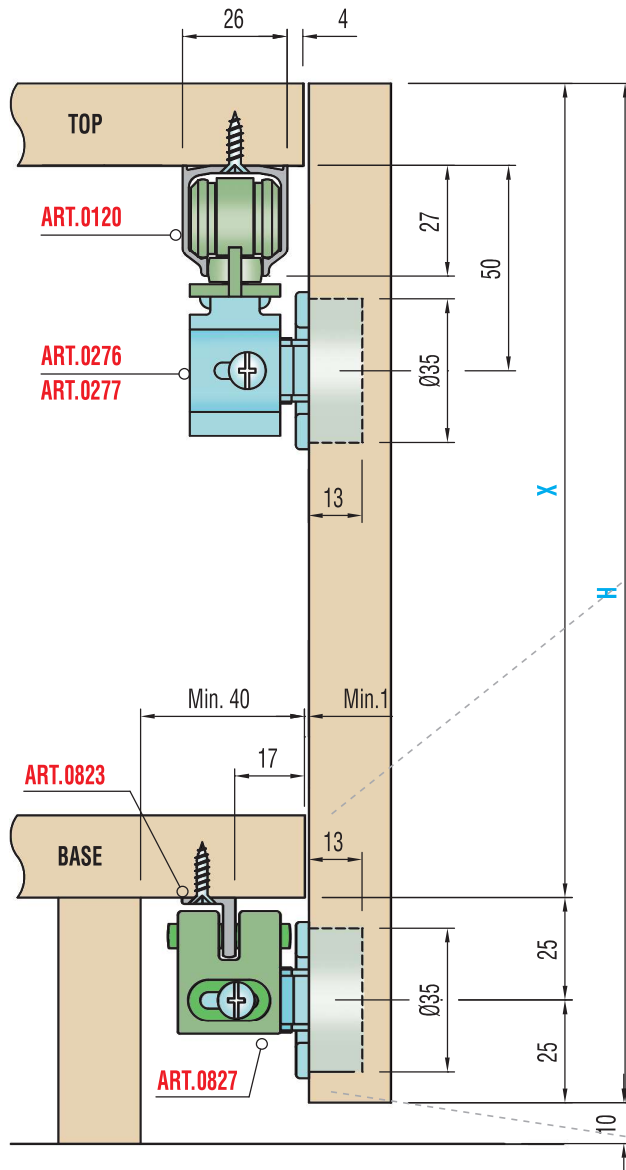

DIMENSIONI ANTE DIMENSIONS OF THE DOORS	
Altezza Height	max. 2000 mm.
Larghezza Width	max. 300 mm.
Spessore Thickness	min. 16 mm. - max. 30 mm.

Variante Special version

Con guida inferiore all'interno del mobile
With lower runner inside the wardrobe

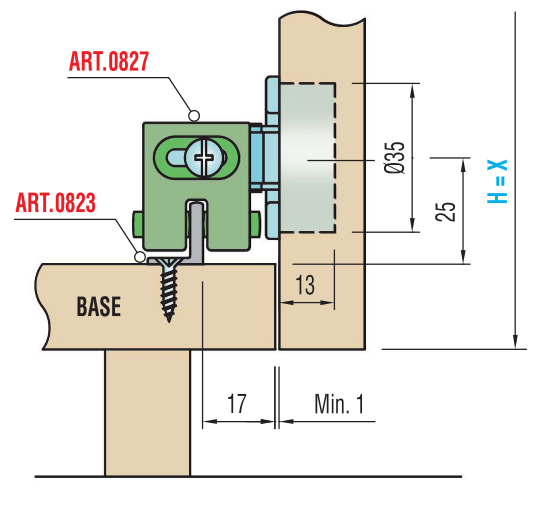

$H = X + 50$

Posizione di montaggio cerniere centrali art. 0809-10

Assembling position of the centre hinges art. 0809-10

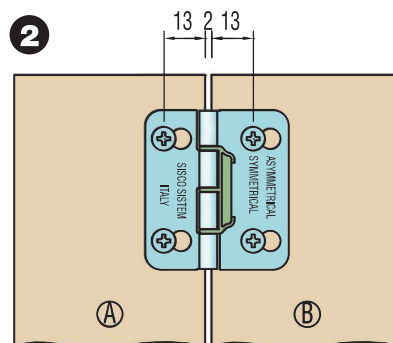
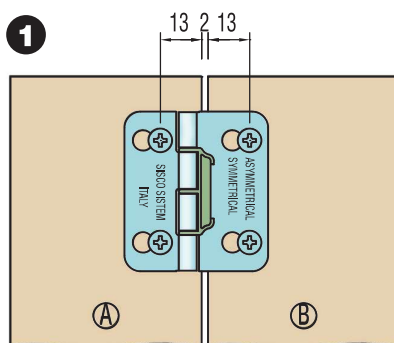

Per il corretto funzionamento del sistema, Vi consigliamo l'uso di cerniere laterali con apertura a 110°, in abbinamento alle cerniere centrali, ART.0809-10, montate in modo asimmetrico (1). Se invece utilizzate cerniere laterali con apertura a 90°, montate le cerniere centrali, ART.0809-10, in modo simmetrico (2).

To ensure a proper functioning of the system, we suggest you to use side hinges with 110° opening, along with centre hinges, ART.0809-10, asymmetrically fitted (1). If you use side hinges with 90° opening, fit centre hinges, ART.0809-10, symmetrically (2).



Schema foratura ante / Doors drilling

CON GUIDA INFERIORE ALL'INTERNO DEL MOBILE / WITH LOWER RUNNER INSIDE THE WARDROBE

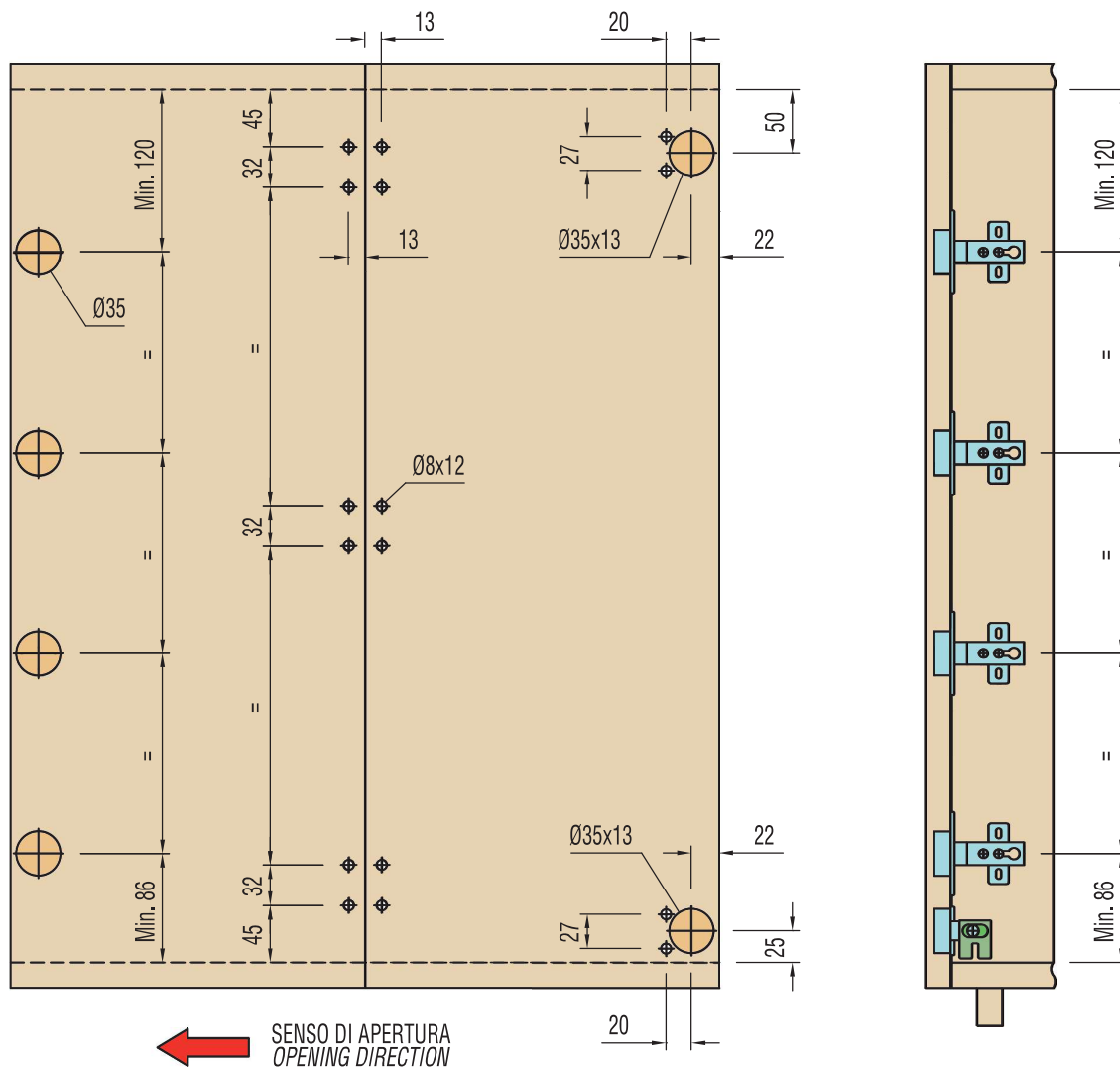

Con guida inferiore all'esterno del mobile / With lower runner outside the wardrobe

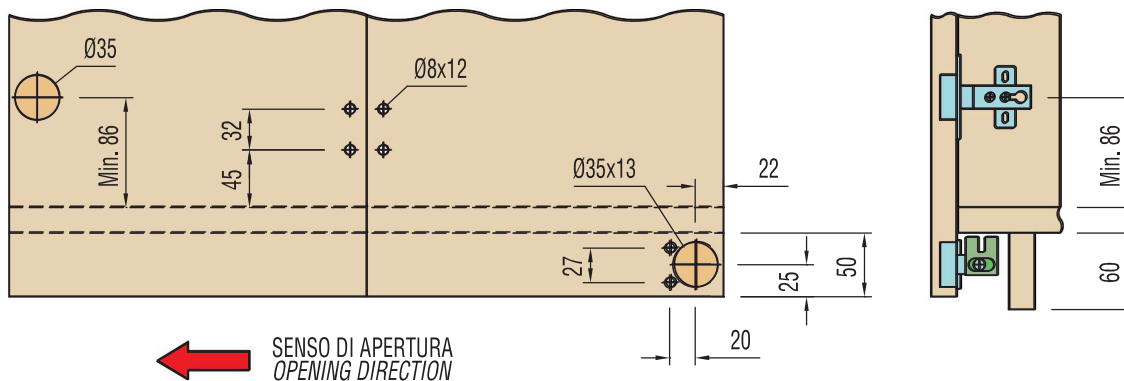

Il peso delle ante deve essere sostenuto dalle cerniere laterali montate sulla spalla del mobile e non dal carrello superiore, che ha la sola funzione di guida. Consultate il vostro fornitore per determinare quante cerniere devono essere montate sulla spalla del mobile, in funzione delle dimensioni e del peso delle vostre ante.

The weight of the doors is born by the side hinges fitted to the wardrobe side, not by the upper truck which only functions as a guide. Turn to your supplier for the quantity of hinges which must be fitted to the wardrobe side, depending on the dimensions and weight of your doors.

SERIE 200 Il nuovo pieghevole

SERIES 200 The new folding door



Sistemi pieghevoli per mobili / Folding systems for furniture

Sezione verticale / Vertical section

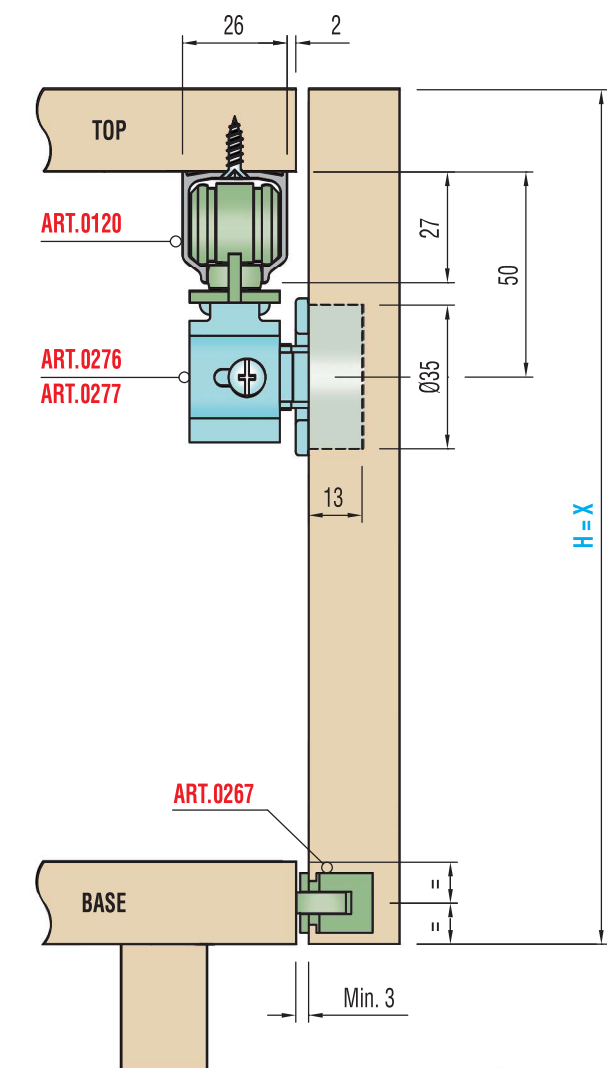

DIMENSIONI ANTE DIMENSIONS OF THE DOORS	
Altezza Height	max. 2000 mm.
Larghezza Width	max. 300 mm.
Spessore Thickness	min. 16 mm. - max. 30 mm.

128

Serie 200

Dimensione minima di ingombro / Minimum overall dimension

CON ANTE SPESSORE 20 mm
WITH DOOR THICKNESS OF 20 mm.

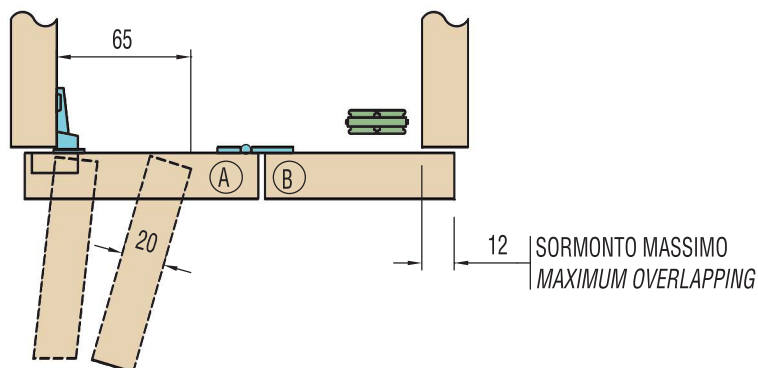

Schema di montaggio / Assembling

SCHEMA MONTAGGIO

Inserire il carrello superiore (ART.0276-0277-0278-0279) nel binario superiore ART.0120.

Avvitare il binario sul top all'interno del mobile e successivamente fissare il carrello superiore all'apposita cerniera precedentemente montata sull'anta.

ASSEMBLING

Fit the upper truck (ART.0276-0277-0278-0279) into the upper profile ART.0120. Screw the profile onto the top, inside the wardrobe, and then fasten the upper truck to the corresponding hinge fitted to the door.

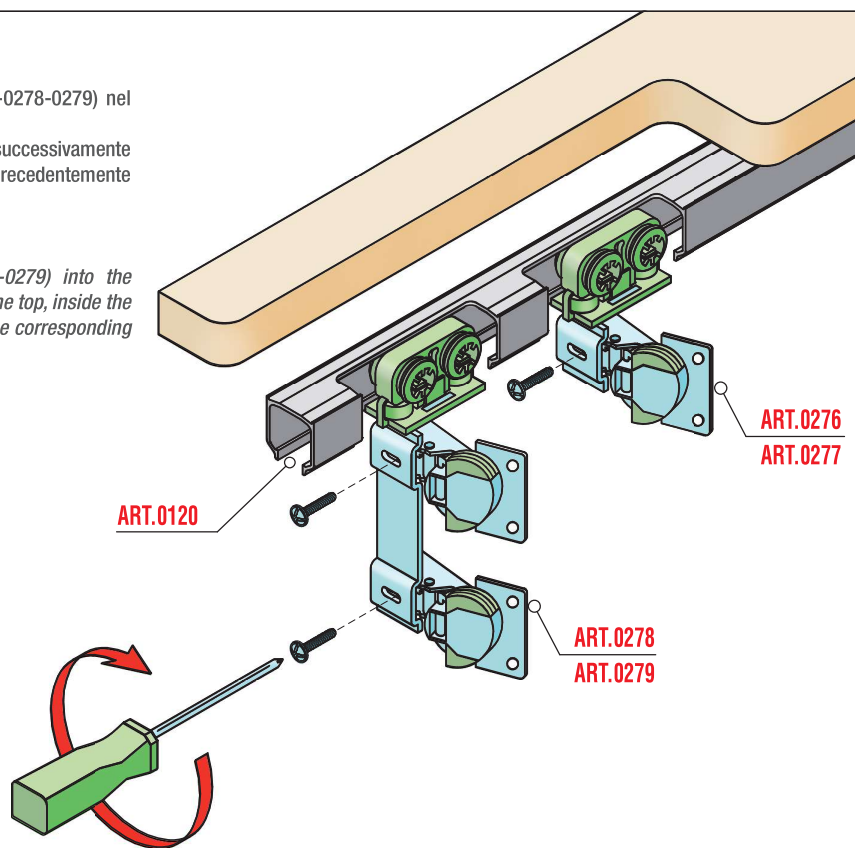

SCHEMA MONTAGGIO

Avvitare il profilo ART.0823 sulla base del mobile.

Tenere la guida ART.0827 nella corretta posizione sul profilo ART.0823 ed avvitare all'apposita cerniera precedentemente montata sull'anta.

ASSEMBLING

Screw the profile ART.0823 to the furniture base.

Hold the runner ART.0827 in the proper position on the profile ART.0823 and screw it to the hinge previously fitted to the door.

